



# Edge welded bellow data sheet

**Part name: KF40EWB-10**

**Part number: 305443**

**date: 01.11.2016**

Geometric dimensions			Technical specifications		
Inner diameter	[mm]	39	Vacuum side	Inside	
Outer diameter	[mm]	59	Helium leak rate	[mbar·l/s]	1·10 <sup>-9</sup>
Assembly length L min	[mm]	33.5	Operating temperature	[°C]	20
Assembly length L max	[mm]	43.5	Bakeout temperature	[°C]	80
Axial stroke	[mm]	10	Total weight	[g]	22
Number of convolutions		7	Spring constant axial	[N/mm]	9.3
End piece length L1	[mm]	15	Tensile force axial*	[N]	16
End piece length L2	[mm]	15	Resulting force axial**	[N]	212
<b>Materials</b>			* required force to pull to maximum assembly length		
bellow	316L		** required force to hold on maximum assembly length during evacuation of the inner volume		
End pieces/ Flanges	316L		Number of cycles	10'000	

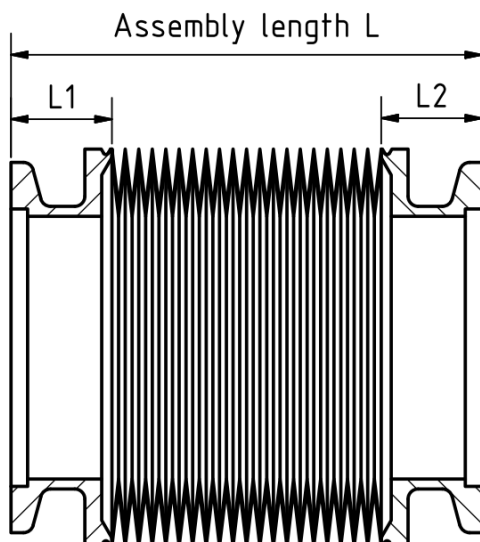

**Important note:**

Number of cycles is describing the maximum number of strokes during the life time. Improper installation or use of the bellows out of specifications result in a reduction of life time. Please avoid especially any torsional load and pollution with particles