



Edge welded bellow data sheet

Part name: KF40EWB-60

Part number: 402727

date: 01.11.2016

| Geometric dimensions | | | Technical specifications | | |
|------------------------|------|-----|--|------------|--------------------|
| Inner diameter | [mm] | 39 | Vacuum side | Inside | |
| Outer diameter | [mm] | 59 | Helium leak rate | [mbar·l/s] | 1·10 ⁻⁹ |
| Assembly length L min | [mm] | 45 | Operating temperature | [°C] | 20 |
| Assembly length L max | [mm] | 105 | Bakeout temperature | [°C] | 80 |
| Axial stroke | [mm] | 60 | Total weight | [g] | 96 |
| Number of convolutions | | 30 | Spring constant axial | [N/mm] | 2.2 |
| End piece length L1 | [mm] | 15 | Tensile force axial* | [N] | 33 |
| End piece length L2 | [mm] | 15 | Resulting force axial** | [N] | 229 |
| Materials | | | * required force to pull to maximum assembly length | | |
| bellow | 316L | | ** required force to hold on maximum assembly length during evacuation of the inner volume | | |
| End pieces/ Flanges | 316L | | Number of cycles | 10'000 | |

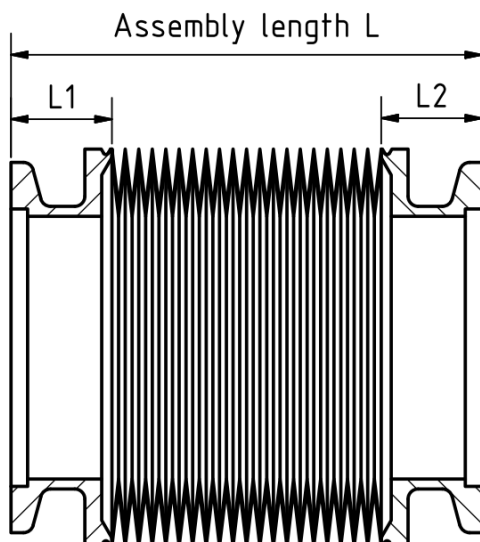

Important note:

Number of cycles is describing the maximum number of strokes during the life time. Improper installation or use of the bellows out of specifications result in a reduction of life time. Please avoid especially any torsional load and pollution with particles